

JB-4-RD

Commercial Electrical Waterproof Box

MODEL NO.	TYPE	PROJECT/DATE
-----------	------	--------------

PRODUCT DESCRIPTION:

Commercial Electric weatherproof boxes are designed for use in branch circuit wiring in wet, damp or dry locations. Boxes house receptacles, switches and GFCI's. Boxes may also be used as a weatherproof junction box. Closure plugs and installation hardware included.



FEATURES:

- State of the art powder coat finish provides maximum weather ability and scratch-resistance
- Rugged die-cast construction
- Internal hub threads comply with NEMA requirements and will accept 1/2 in. threaded fittings and threaded conduit
- NEMA 3R compliant



DIMENSIONS:

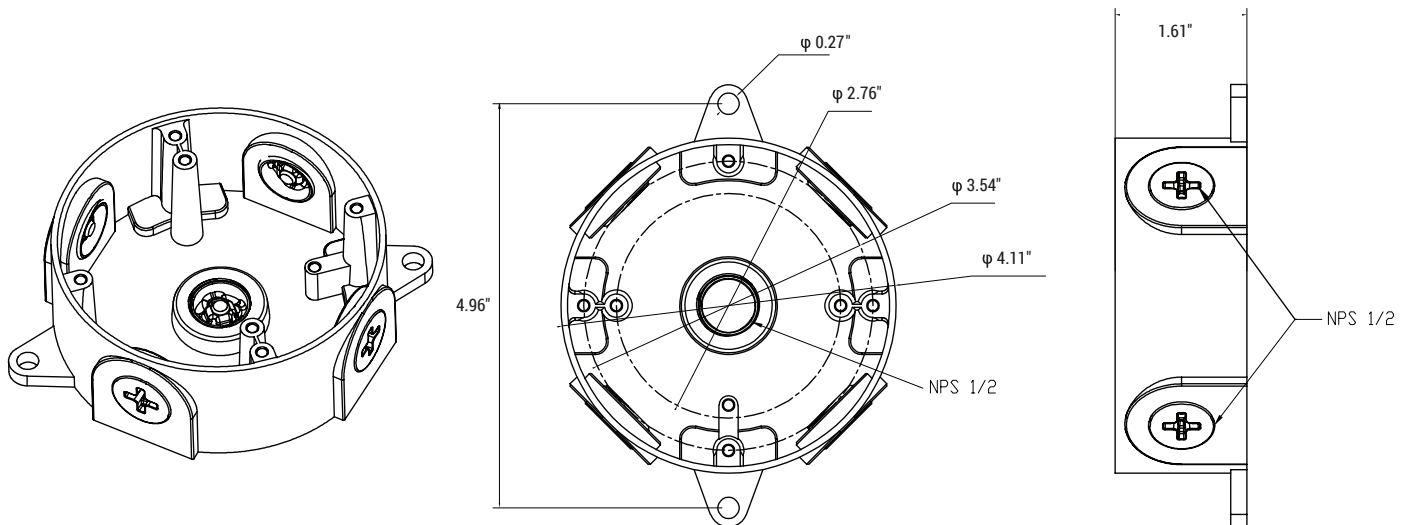

SERIES	SIZE	SHAPE	FINISH
JB - Junction Box	4 - 4"	R- Round	WH - White DB - Dark Bronze BL - Black AL - Aluminum