

UL924 Emergency Lighting Bypass/Shunt Load Non-Dim

Overview

- UL924 Bypass Relay
- For Non-Dim Loads
- Mounts On Electrical Enclosure
- Local Test Button
- Dry Contact Input For Override
- Green LED Normal Power
- Yellow LED Load Power
- Red LED Emergency Power
- Remote Test Input
- 20 Amp Automatic Load Control



Suitable For Indoor Only



Applications

The ESRN-1 is a UL924 Emergency Bypass Shunt Load Relay for Non-Dim Loads. Under normal power conditions the load is controlled by mwConnect fixture controllers, occupant sensors or wall controls. This allows operation of switching, energy saving strategies and automatic shutoff for normal operation. When normal power is not present, emergency lights automatically turn on to full power output.

Shunt Load Relay Operation

Automatically Turns on Emergency Egress Lighting on Loss of Normal Power: The control circuit in the ESRN UL924 Emergency Bypass Relay constantly monitors normal power. On loss of normal power the Normally Closed contact in the ESRN (Normal/Emergency Power) will close and the On/Off switch or Fixture Controller will be disabled forcing the light ON to full power output.

Test button: There is a test button on the ESRN to simulate loss of normal power.

Contact Closure Input: Contact closure input allows for allows for a button (not included), switch, controller, or fire alarm panel, to trigger the emergency lights from a remote location.

Accessories

Remote Test Button: ESRTB (sold separately).

Summary

Relay Type:
UL924 Bypass Shunt Load SPST

Input Voltage Normal:
120-277VAC

Input Voltage Normal/Emergency
120-277VAC

Housing Rating:
UL Accepted for Use in Plenum, NEMA 1

Load:
@ 120/277VAC Max. 20 Amp, Mag Ballast
@ 120/277VAC Max. 16 Amp E. Ballast, LED
@ 120/277VAC Max. 10 Amp Tungsten

Operating Temperature:
-30° to 140°F
-34° to 60°C

Relative Humidity:
5-95% (noncondensing)

Color: Yellow

Warranty: 5 years

Project

Location/Type

Physical Dimensions

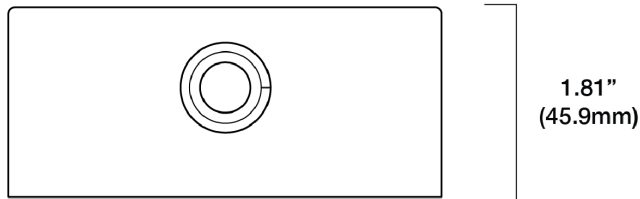
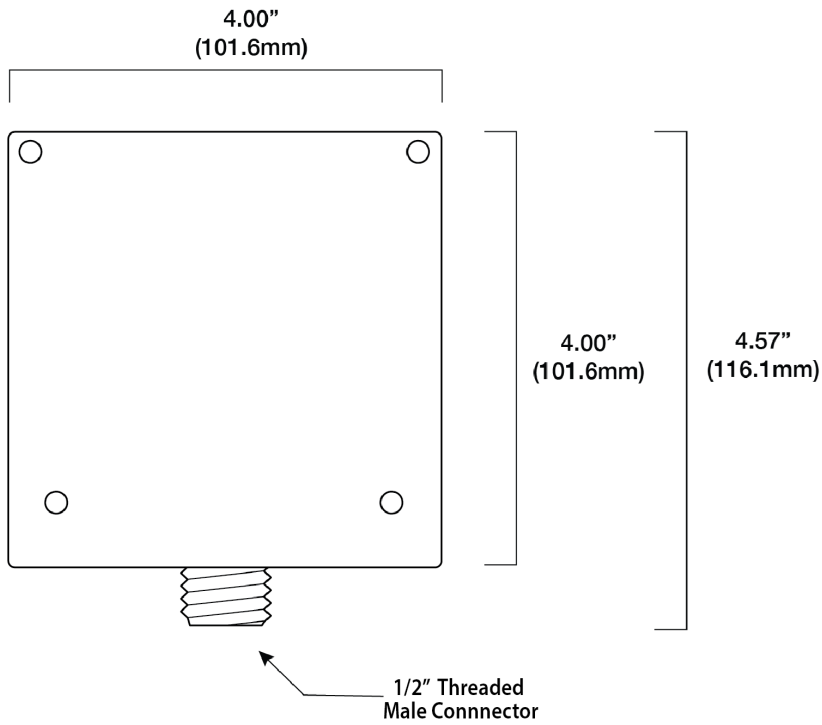

Drawings Are Not To Scale

LED And Test Button

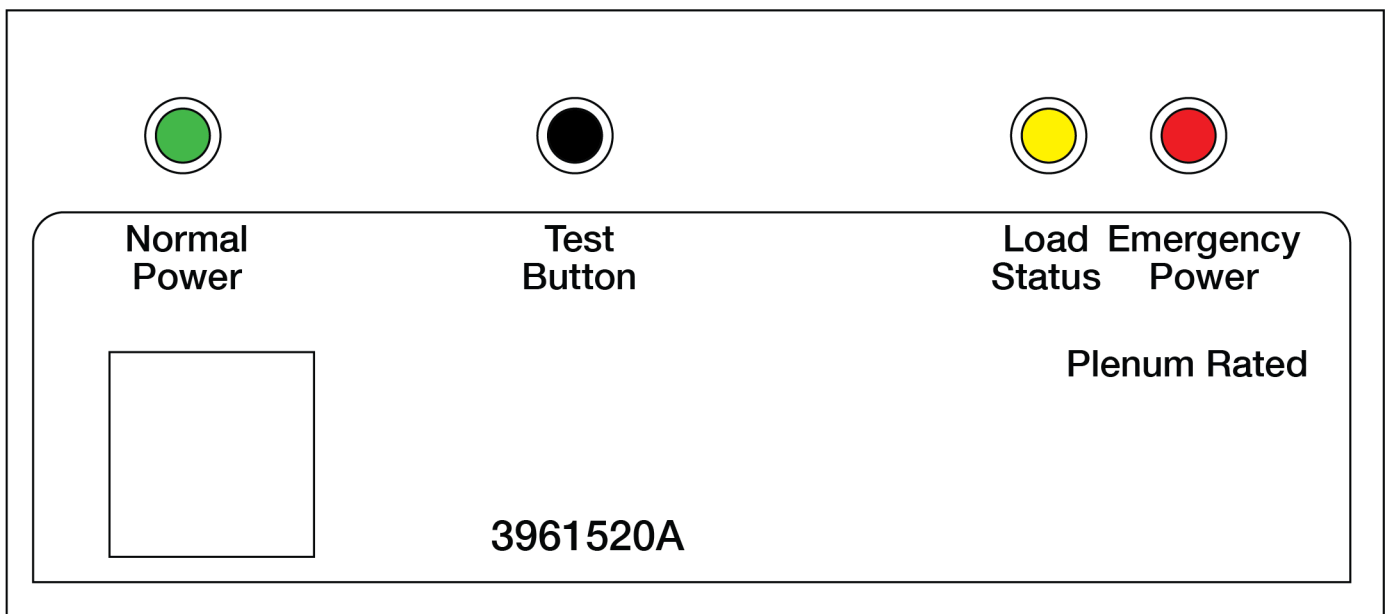

Application Example: Normal and Normal/Emergency Lighting Fixtures Controlled Switch And Occupancy Sensor

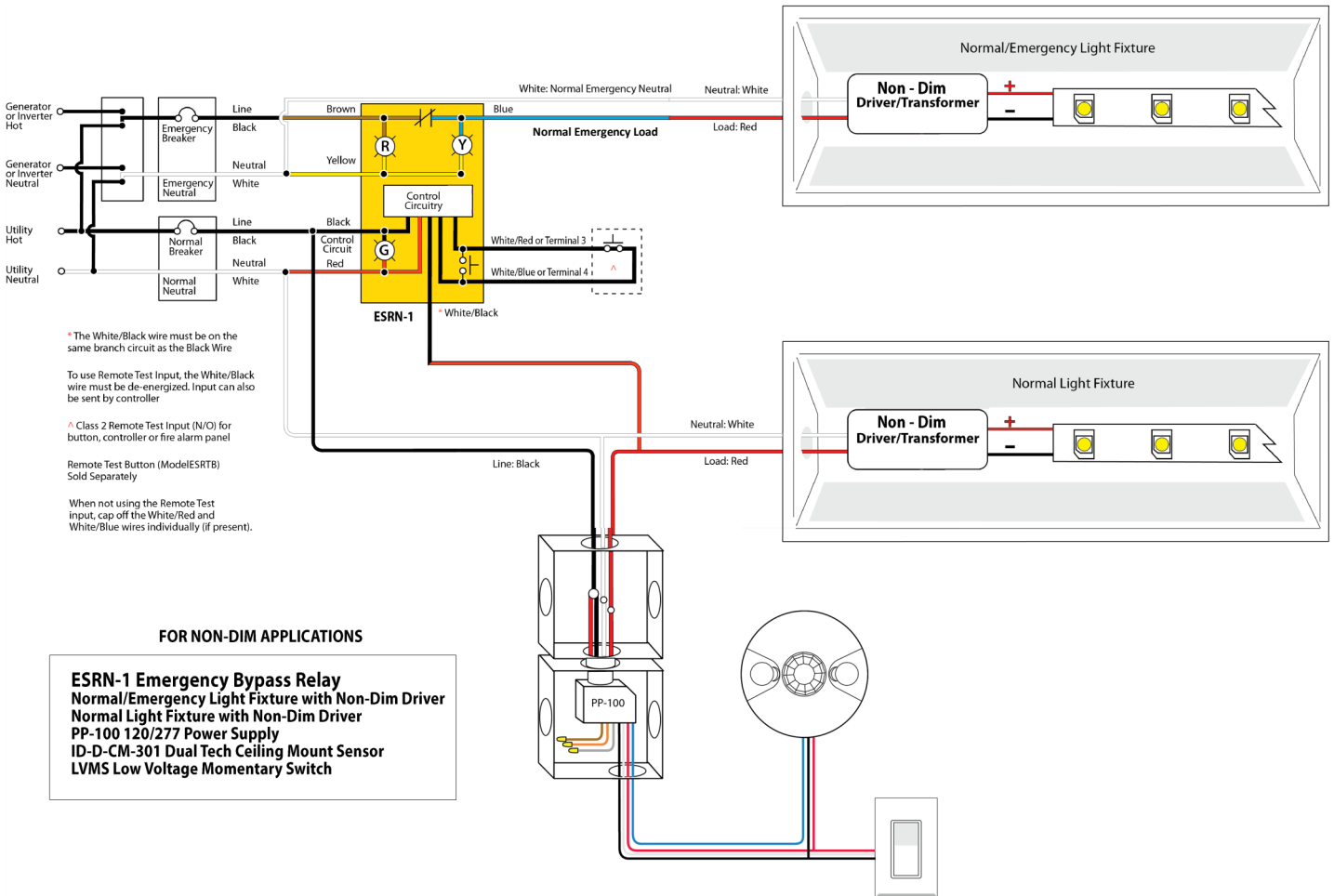

Wiring Table: 16" leads, 600V rated

ESRN-1 Wiring Table			
Wire	Description	Notes	Between ESRN-1 And Source
Black	Normal Hot	Connect to Line Power (same input as controller)	NEC Standard Hot 120 or 277
White/Black	Normal Hot "T" From Above	Connect to Load Side of Controller "Wall Switch"	Same As Above
Red	Neutral Input	Connect to Neutral (same input as controller)	NEC Standard Neutral 120 or 277
Red	Load Neutral "T" From Above	Connect to Normal Luminaire Power Input	NEC Standard Hot 120 or 277
Brown	Normal/Emergency Hot	Connect to Normal/Emergency Line Power	NEC Standard Hot 120 or 277
Blue	Normal/Emergency Load Neutral	Connect to Normal/Emergency Luminaire Neutral	NEC Standard Hot 120 or 277
Yellow	Normal/Emergency Neutral	Connect to Normal/Emergency Neutral (and fixture hot)	NEC Standard Hot 120 or 277
Terminal 3	Optional Interface to Fire Alarm or ESRTB Test Button	N/O Switch for Fire Alarm	Per NFPA or NEC TBD by EE or EC
Terminal 4	Optional Interface to Fire Alarm or ESRTB Test Button	Common	Per NFPA or NEC TBD by EE or EC

Notes:

White/Black: Must be on the same branch circuit as Black and Red. When switched off, a two second delay keeps the load on to test emergency power. Does not test feedback/dimmer output.

Terminal Screw 3.4: When wiring multiple units together, terminal 4 must share a common. Test is performed when input is closed.

Point To Point

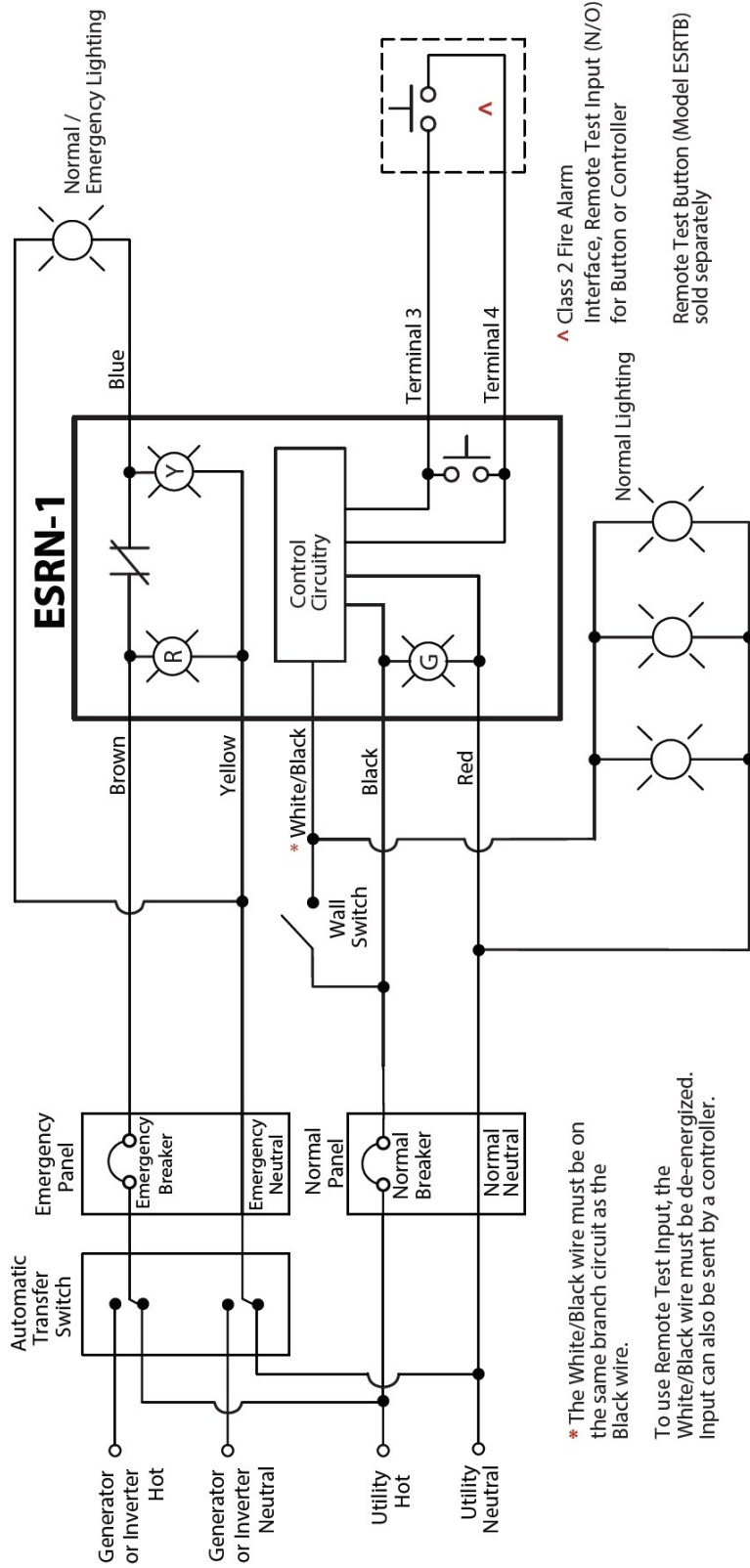

▲ Class 2 Fire Alarm Interface, Remote Test Input (N/O) for Button or Controller
 Remote Test Button (Model ESRTB) sold separately

* The White/Black wire must be on the same branch circuit as the Black wire.
 To use Remote Test Input, the White/Black wire must be de-energized. Input can also be sent by a controller.

Testing

Initial Test for Correct Wiring

Apply Emergency Power to the Emergency Power Input and Normal Power to the Normal Power Input. (If using the Wall Switch Input, apply Normal Power to the switch also, but keep the switch OFF/OPEN.)

- a. The Red LED (Emergency Power available) should be ON.
- b. The Green LED (Normal Power available) should be ON.
- c. The Yellow LED (Load Status) should be OFF.
- d. The Load should be OFF.
- e. The Feedback/Dimmer Contact should be CLOSED.

Local Test Button

1. Turn switched circuit OFF. Emergency light should be OFF.
2. Press and hold "Local Test Button"
3. Emergency light should turn ON.
4. Release "Local Test Button" and emergency light should turn OFF.

Remote Test Button (Model ESRTB - sold separately)

1. Turn switched circuit OFF. Emergency light should be OFF.
2. Press and hold "Remote Test Button"
3. Emergency light should turn ON.
4. Release "Remote Test Button" and emergency light should turn OFF.

Wall Switch or Controller Contact

1. Turn ON switch if not already on.
2. Emergency light should turn ON.
3. Turn wall switch OFF.
4. Emergency light will remain on for two seconds before turning OFF.

How To Order

Model No.	Description	Input Voltage
ESRN-1	UL924 Automatic Bypass Shunt Load Relay for Non-Dim Loads	120-277 VAC
ESRTB	Remote Test Button	

Design and specifications are subject to change without notice.